

MCM

MCM S70 FORKLIFT

TOGETHER, THE FUTURE IS BUILT



MCM

TECHNICAL SPECIFICATIONS

MCM S70 FORKLIFT

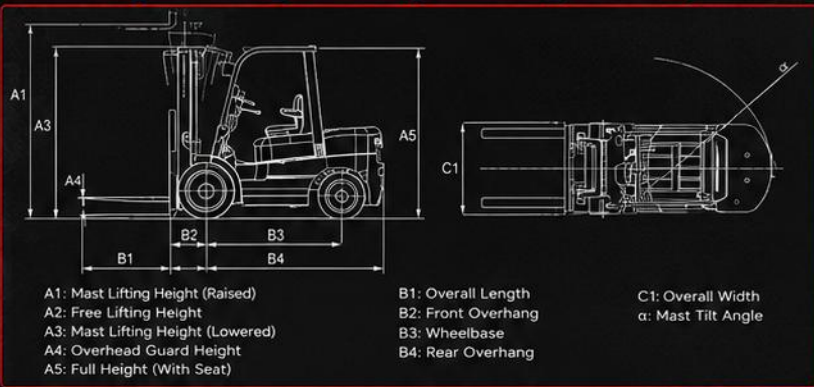

7.0 TON PERFORMANCE PARAMETERS

- Adopt a new design style
- Bold rear legs of the overhead guard to ensure the safety of the driver
- The design accords with ergonomics, the driving is comfortable, the field of vision is wide, the operation is sensitive
- Hydraulic system of priority valve is configured to effectively improve the lifting speed
- Using integrally cast steering axle and drive axle to improve the reliability of the whole vehicle
- Using solid counterweight, the turning radius is greatly reduced

S70 PERFORMANCE PARAMETERS

| 1 | | Model | | CPCD70 | | | |
|----------------------|------------------|--------------------------------|-------------------|--------------------|----------|-----------|--|
| General | 1 | Rated Load Capacity | kg | 7000 | | | |
| | 2 | Load Center | mm | 600 | | | |
| | 3 | Lifting Height (A2) | mm | 3000 | | | |
| | 4 | Free Lifting Height (A4) | mm | 200 | | | |
| Dimensions | 5 | Fork Size (B1) | LxWxT | 1220X150X65 | | | |
| | 6 | Mast Tilting Angle | F/R | 6/12 | | | |
| | 7 | Length (without fork) (B4) | mm | 3550 | | | |
| | 8 | Overall Width (C1) | mm | 1950 | | | |
| | 9 | Mast High After Mast Fall (A3) | mm | 2500 | | | |
| | 10 | Full Height (A1) | mm | 4365 | | | |
| | 11 | Overhead Guard Height (A5) | mm | 2450 | | | |
| | 12 | Turning Radius (C2) | mm | 3300 | | | |
| | 13 | Front Overhang (B2) | mm | 800/710 | | | |
| | 14 | Min.Right Angle Channel Width | mm | 3040 | | | |
| Performance | 15 | Wheelbase (B3) | mm | 2250 | | | |
| | 16 | Track | Front | mm | 1470 | | |
| | | | Rear | mm | 1700 | | |
| | 18 | Ground Clearance | Mast | mm | 232 | | |
| | | | Full Load | Km/h | 28 | | |
| | 21 | Travel | No Load | Km/h | 33 | | |
| | | | Full Load | mm/s | 420 | | |
| | | 23 | Lifting | No Load | mm/s | 450 | |
| | | | | Full Load | mm/s | 380 | |
| | | 25 | Lowering | No Load | mm/s | 350 | |
| Max.Drawbar Pull | | | | Full/No Load | kg | 5300/2300 | |
| 27 | Max.Gradeability | Full/No Load | % | 15/20 | | | |
| | | Front Tire | | Front 15-14PR | | | |
| 30 | Rear Tire | | | 8.25-15-14PR | | | |
| | | 31 | Total Weight | kg | 9170 | | |
| Power & Transmission | 32 | Battery Voltage/Capacity | V/AH | 24/130 | | | |
| | 33 | Engine | Model | Quanchai 4J1-T1G32 | | | |
| | | | Rated Power/Speed | Kw/rpm | 65/2200 | | |
| | | | Max.Torque/Speed | N.m/rpm | 500/1600 | | |

7.0t 2 STAGE MAST

| Mast Height | Carrying Capacity (500mm)kg | Mast Height After Mast Fall | Free Lifting Height (mm) | Full Mast Full Height (mm) | Mast Tilting Angle (F/R) | Total Weight (kg) |
|-------------|-----------------------------|-----------------------------|--------------------------|----------------------------|--------------------------|-------------------|
| 2700 | 6000 | 2350 | 200 | 4070 | 6°-12° | 9279 |
| 2750 | 6000 | 2375 | 200 | 4120 | 6°-12° | 9293 |
| 3000 | 6000 | 2500 | 200 | 4370 | 6°-12° | 9320 |
| 3250 | 6000 | 2625 | 200 | 4620 | 6°-12° | 9360 |
| 3300 | 6000 | 2650 | 200 | 4670 | 6°-12° | 9389 |
| 3500 | 6000 | 2750 | 200 | 4870 | 6°-12° | 9401 |
| 3750 | 6000 | 2875 | 200 | 5120 | 6°-12° | 9442 |
| 4000 | 6000 | 3055 | 200 | 5370 | 6°-12° | 9606 |
| 4250 | 6000 | 3175 | 200 | 5620 | 6°-12° | 9648 |
| 4500 | 6000 | 3300 | 200 | 5870 | 6°-12° | 9689 |
| 4750 | 6000 | 3425 | 200 | 6120 | 6°-6° | 9730 |
| 5000 | 6000 | 3550 | 200 | 6370 | 6°-6° | 9770 |

Note: (1) Indicates the rated load capacity of double tires on the front wheel
 (2) The parameters are subject to change without prior notice for continuous improvement.



Website: www.MCMGROUP.co.za



Instagram: @mcm.company



Facebook: MCM Group

CAPE TOWN

9 Karee Rd, Kraaifontein Industria,
Cape Town, 7570

SALES (+27) 21 001 8686

ruan@mcmco.co.za

GEORGE

Jura Lands, Beach Road,
Hansmoeskraal, George, 6529

SALES (+27) 44 878 2917

chris@mcmco.co.za

FREE STATE

Bloem Showgrounds, Curie Avenue,
Generaal De Wet, Bloemfontein, 9301

SALES (+27) 84 022 7300

clarence@mcmco.co.za

GAUTENG

26 Sterling Rd, Unit 1,
Samrand Business Park, Midrand, 0117

SALES (+27) 12 030 3451

sales@mcmco.co.za